

The Cost Effective Approach to Quality Filtration

FTC introduces its new EASEE SYSTEM utilizing absolute rated filtration and coalescing for liquid streams.

This unique design, based on U.S. Patent Nos. 5160442 & 5824232, uses segregated flow channels and flow chambers to maximize the effective surface area of the pleated filter media coalescer. Combining this design with the technique of pleating several different filter media together in a single pleat pack maximizes dirt holding capacity while increasing separation efficiency.

Available in a variety of sizes and filter media efficiencies, the coalescing cartridge can be constructed with metal end caps and core for high temperature applications.

The FTC EASEE SYSTEM housing and coalescing cartridge is the solution to achieving single pass filtration and separation while minimizing costs.



SEPARATION EFFICIENCY

OIL & GREASE REMOVAL

FLUID TYPE	INFLUENT	EFFLUENT
Bilge Water	57119 ppm	8.9 ppm
Oilfield Produced Water	87 ppm	7.3 ppm
Plant Waste Water	24 ppm	2.1 ppm
Wash Pit Water	66 ppm	11.0 ppm

TYPICAL FLOW DIAGRAM

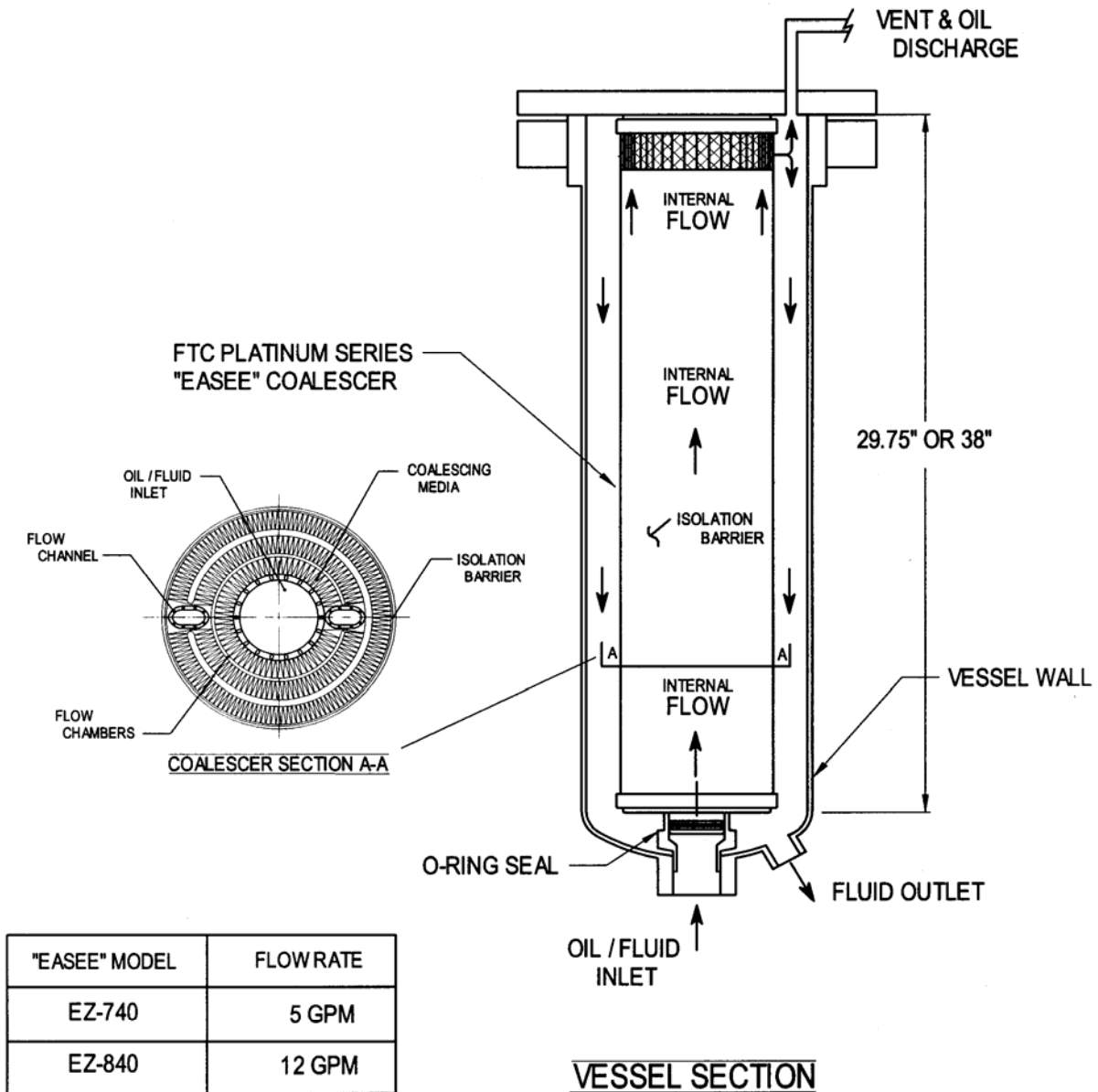

Notice: The information presented here is based on tests and data which FTC believes to be reliable, but their accuracy or completeness is not guaranteed. FTC MAKES NO WARRANTIES, EXPRESS OR IMPLIED, BUT NOT LIMITED TO, ANY IMPLIED WARRANTY OR MERCHANTABILITY OR FITNESS FOR A PARTICULAR PURPOSE. The determination of whether the FTC product is fit for a particular purpose or application is the responsibility of the user.

FORM EASEE 7/07

Filtration Technology Corporation



5175 Ashley Court
Houston, Texas 77041
(713) 849-0849 • 888-436-0849 • FAX (713) 849-0202
www.ftc-houston.com