



# TLP SERIES INTERNAL PIPELINE FILTER

## The Cost Effective Approach to Quality Filtration

FTC introduces its new TLP Series filtration system for pipeline filtration (Patent Pending). This exciting new product combines our proven Platinum Technology with an innovative new proprietary filtration system designed to utilize existing pig launching equipment.

TLP Series system is designed to offer a low-cost solution for temporary filtration needs associated with pigging operations. Use of the TLP Series system can reduce costs by protecting expensive downstream equipment and coalescing systems from contaminants introduced during pigging operations, and can also reduce the size of temporary fluid handling systems required for liquid pipeline pigging operations.

The TLP Series can be custom designed to offer maximum contaminant holding capacity without the need for additional filter vessels, thus reducing operating costs. The patented Platinum technology uses segregated flow channels and flow chambers to maximize the effective surface area of the pleated filter media within a given OD cartridge. Combining this technology with FTC's wide variety of media, filter sizes, and end cap configurations provide customers with the optimal filtration solution for their specific application.

Superior construction materials and quality control techniques ensure that FTC Filter Cartridges will provide quality filtration, even in harsh operating conditions. Most TLP Series elements are constructed with metal end caps and core, and with selection of the proper media may be used for high temperature applications.

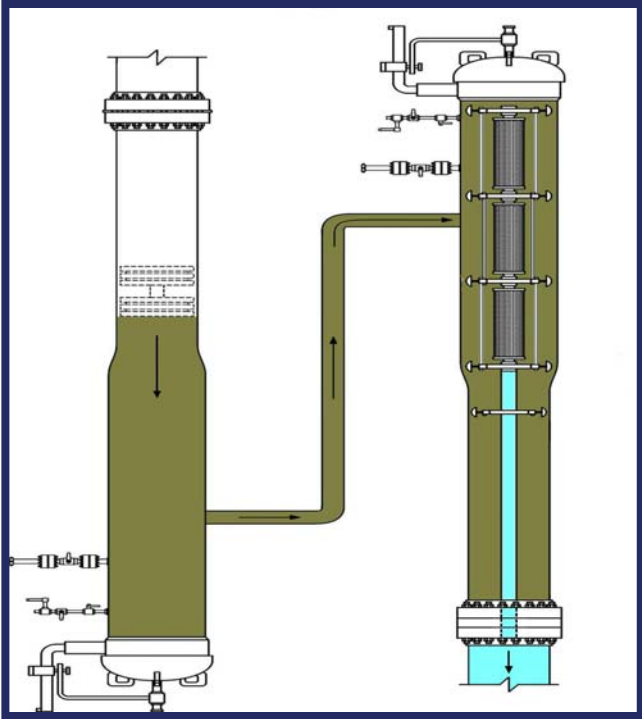

### INCREASING FILTER LIFE

**DOUBLING FILTER SURFACE AREA CAN INCREASE FILTER LIFE UP TO FOUR TIMES:**

FILTER LIFE INCREASE =

$$\frac{Le}{Lo} = \left( \frac{Ae}{Ao} \right)^N$$

- Le = Extended Filter Life
- Lo = Original Filter Life
- Ae = Expanded Filter Area
- Ao = Original Filter Area
- 1 ≤ N ≤ 2

# TLP SERIES FILTRATION SYSTEM

LOADING OF  
CONNECTION  
NOZZLE

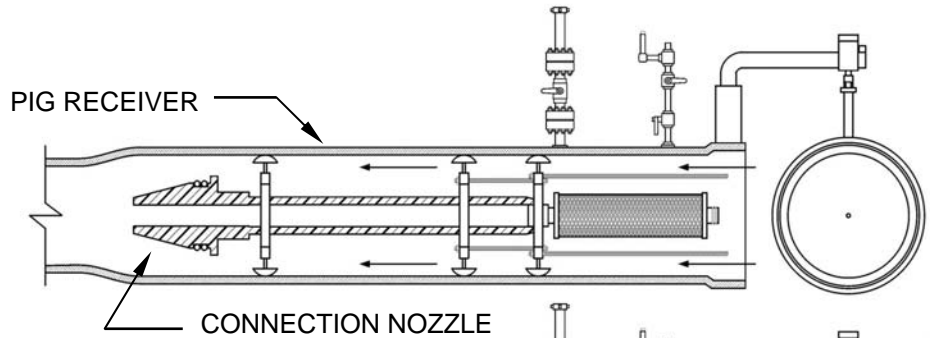

LOADING OF  
"PLATINUM" SERIES  
INTERNAL PIPELINE  
FILTER

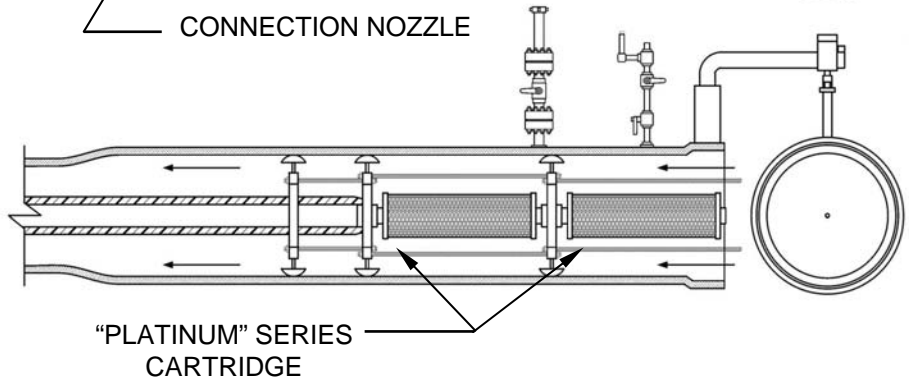

LOADING OF  
"PLATINUM" SERIES  
INTERNAL PIPELINE  
FILTER

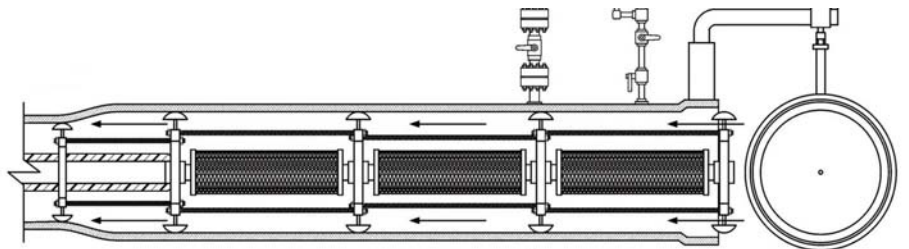

LOADING OF  
"PLATINUM" SERIES  
FILTERS COMPLETE,  
RECEIVER CLOSED

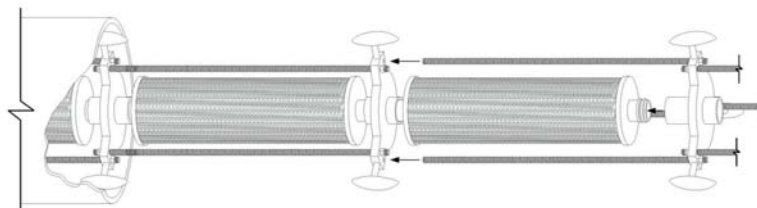
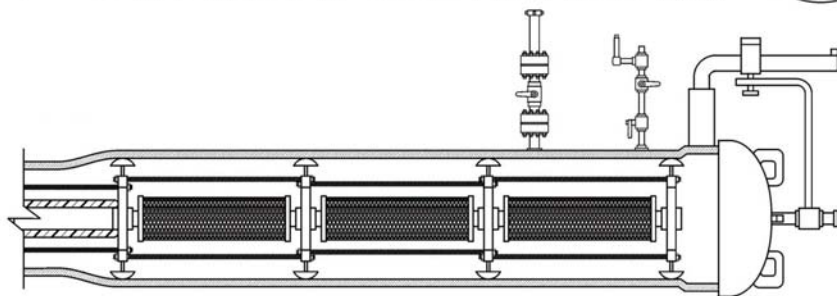

TYPICAL FILTER SUPPORT SYSTEM

Notice: The information presented here is based on tests and data which FTC believes to be reliable, but their accuracy or completeness is not guaranteed. FTC MAKES NO WARRANTIES, EXPRESS OR IMPLIED, BUT NOT LIMITED TO, ANY IMPLIED WARRANTY OR MERCHANTABILITY OR FITNESS FOR A PARTICULAR PURPOSE. The determination of whether the FTC product is fit for a particular purpose or application is the responsibility of the user.



FORM TLP SERIES 7/07

**Filtration Technology Corporation**

5175 Ashley Court  
Houston, Texas 77041  
(713) 849-0849 • 888-436-0849 • FAX (713) 849-0202  
[www.ftc-houston.com](http://www.ftc-houston.com)